

The Impressor

The Barcol Impressor Hand-Held Portable Hardness Tester

- Aluminum
- Aluminum Alloys
- Soft Metals
- Plastics
- Fiberglass



Introduction

Portable

The Impressor is a convenient tool for testing the hardness of aluminum, aluminum alloys, copper, brass and other materials including plastics and fiberglass. The instrument is designed for use on fabricated parts and assemblies as well as on raw stock.

Easy to Use

No experience required; can be used in any position and in any space that will allow for the operator's hand. The hardness reading is instantly indicated on the dial, which is divided into one hundred graduations. No waiting, pre-loading or separate measurements.

Lightweight

The impressor weighs only 1 lb. 2 oz. and comes complete with carrying case, adjusting wrench and two spare indenter points, 2 lb. 8oz.

Applications

Four Models Available

GYZJ 934-1 for soft metals such as aluminum and its alloys, brass, copper, and some of the harder plastics and fiberglass. Approximate range 25 to 150 Brinell (10 mm ball 500 kg load). This unit meets American Society for Testing and Materials (ASTM) Standard D-2583.

GYZJ 934-1-0-1 for ladder testing. Compliant with **NFPA 1932**, National Fire Protection Association – 1994 Edition; **ASTM B648-76**, American Society for Testing and Materials – 1984 edition.

GYZJ 935 for the softer plastics and very soft metals.

GYZJ 936 for extremely soft materials such as lead, linoleum and leather.

Barber-Colman engineers will be glad to recommend the most suitable model upon receipt of sample materials.

Operating Information

The Impressor is best suited for testing homogeneous materials. Materials of granular, fibrous or coarse structure will produce a wide variation in hardness readings because of the small diameter of the indenter point.

For accurate readings, material should be at least 1/32" thick and large enough for a minimum distance of 1/8" in any direction from the indenter point to the edge of the specimen. The testing area should be smooth and free from mechanical damage.

Simply exert a light pressure against the instrument to drive the spring-loaded indenter point into the material. The indenter point must be perpendicular to the surface being tested.

On very soft metals, the highest reading should be used since cold flow permits the spring-loaded indenter point to continue penetration.

The Impressor

Operating Information (continued)

Note: Physical characteristics of very soft materials are such that uniform correlation between different hardness measuring systems cannot be established. For this reason, no conversion curves are offered for the 935 and 936 models. We recommend that impressor hardness limits for each material be established by test.

Recommended Sample Sizes To equalize the variance of the average (GYZJ 934-1)

| | Hardness Scale | Reading Variance | Number of Readings | Variance of Average |
|------------------------------|----------------|------------------|--------------------|---------------------|
| Homogeneous Material: | 20 | 2.47 | 9 | 0.27 |
| | 30 | 2.20 | 8 | 0.28 |
| | 40 | 1.93 | 7 | 0.27 |
| | 50 | 1.66 | 6 | 0.28 |
| | 60 | 1.39 | 5 | 0.28 |
| | 70 | 1.12 | 4 | 0.28 |
| | 80 | 0.85 | 3 | 0.28 |
| Reinforced Plastics: | 30 | 22.4 | 29 | 0.77 |
| | 40 | 17.2 | 22 | 0.78 |
| | 50 | 12.0 | 16 | 0.75 |
| | 60 | 7.8 | 10 | 0.78 |
| | 70 | 3.6 | 5 | 0.75 |

Typical Readings of Aluminum Alloys

| | | | | | | | | |
|---------------------|--------|--------|---------|--------|--------|---------|--------|--------|
| Alloy and Temper: | 1100-0 | 3003-0 | 3003H14 | 2024-0 | 5052-0 | 5052H14 | 6061T6 | 2024T3 |
| GYZJ 934-1 reading: | 35 | 42 | 56 | 60 | 62 | 75 | 80 | 85 |

Approximate Conversion Curves for GYZJ 934-1

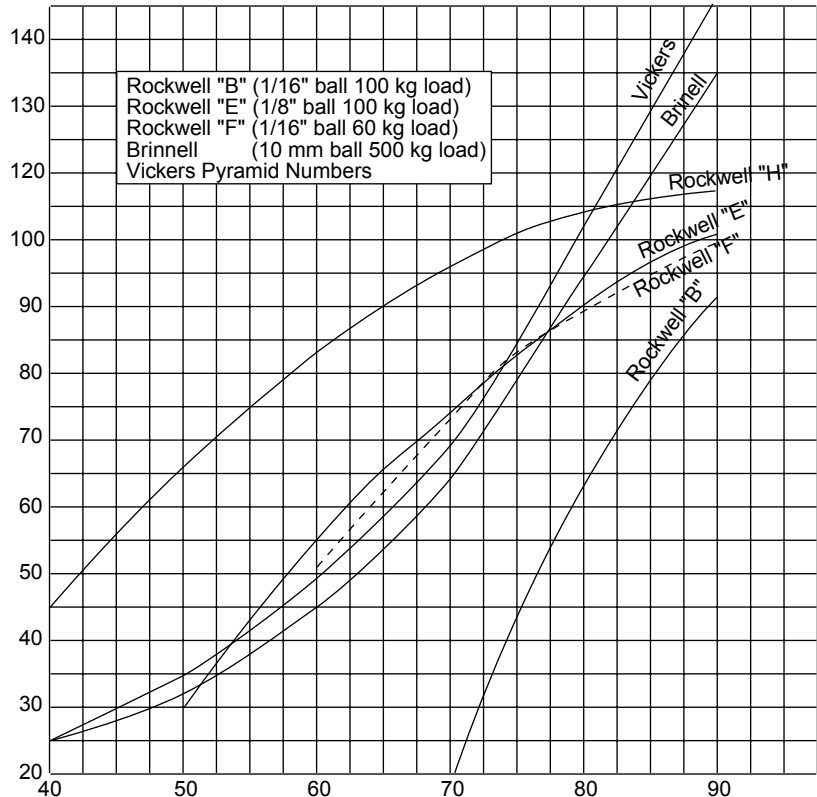

The Impressor

Operating Information (continued)

Approximate Conversion Chart for GYZJ 934-1

| 934-1 | Brinnell | Vickers | Rockwell | | | |
|-------|----------|---------|----------|----|----|----|
| | | | B | E | F | H |
| 35 | | 23 | | | | 32 |
| 36 | | 23 | | | | 33 |
| 37 | | 24 | | | | 37 |
| 38 | | 24 | | | | 40 |
| 39 | | 25 | | | | 43 |
| 40 | 25 | 25 | | | | 45 |
| 41 | 26 | 26 | | | | 47 |
| 42 | 26 | 27 | | | | 49 |
| 43 | 27 | 27 | | | | 52 |
| 44 | 27 | 28 | | | | 54 |
| 45 | 27 | 20 | | | | 56 |
| 46 | 28 | 30 | | | | 58 |
| 47 | 29 | 32 | | 24 | | 61 |
| 48 | 30 | 33 | | 25 | | 63 |
| 49 | 31 | 34 | | 28 | | 64 |
| 50 | 32 | 35 | | 30 | | 66 |
| 51 | 33 | 36 | | 33 | | 68 |
| 52 | 34 | 38 | | 36 | | 70 |
| 53 | 35 | 39 | | 39 | 29 | 72 |
| 54 | 37 | 41 | | 42 | 33 | 73 |
| 55 | 38 | 42 | | 44 | 38 | 75 |
| 56 | 39 | 44 | | 46 | 40 | 76 |
| 57 | 40 | 45 | | 48 | 43 | 78 |
| 58 | 42 | 47 | | 51 | 47 | 80 |
| 59 | 44 | 48 | | 53 | 49 | 81 |
| 60 | 45 | 49 | | 55 | 51 | 83 |
| 61 | 47 | 51 | | 57 | 54 | 84 |
| 62 | 48 | 53 | | 59 | 56 | 86 |
| 63 | 50 | 55 | | 62 | 58 | 88 |
| 64 | 52 | 57 | | 64 | 61 | 89 |
| 64 | 54 | 58 | | 65 | 63 | 90 |
| 66 | 55 | 60 | | 67 | 65 | 91 |
| 67 | 58 | 62 | | 69 | 67 | 92 |

| 934-1 | Brinnell | Vickers | Rockwell | | | |
|-------|----------|---------|----------|-----|-----|-----|
| | | | B | E | F | H |
| 68 | 60 | 64 | | 71 | 69 | 94 |
| 69 | 62 | 67 | | 73 | 71 | 95 |
| 70 | 64 | 69 | 18 | 74 | 73 | 96 |
| 71 | 67 | 72 | 19 | 76 | 75 | 98 |
| 72 | 69 | 74 | 28 | 77 | 77 | 99 |
| 73 | 71 | 76 | 33 | 79 | 79 | 100 |
| 74 | 73 | 81 | 39 | 81 | 81 | 101 |
| 75 | 76 | 85 | 45 | 83 | 83 | 102 |
| 76 | 80 | 88 | 48 | 84 | 84 | 103 |
| 77 | 84 | 92 | 52 | 86 | 86 | 104 |
| 78 | 87 | 95 | 56 | 88 | 87 | 105 |
| 89 | 90 | 99 | 60 | 89 | 88 | 106 |
| 80 | 94 | 103 | 63 | 90 | 89 | 107 |
| 81 | 97 | 108 | 65 | 91 | 90 | 108 |
| 82 | 100 | 111 | 69 | 92 | 91 | 108 |
| 83 | 105 | 116 | 72 | 94 | 92 | 109 |
| 84 | 109 | 122 | 75 | 95 | 93 | 109 |
| 85 | 113 | 127 | 77 | 96 | 94 | 110 |
| 86 | 117 | 133 | 80 | 97 | 95 | 111 |
| 87 | 122 | 137 | 83 | 98 | 96 | 111 |
| 88 | 126 | 142 | 86 | 99 | 97 | 112 |
| 89 | 131 | 144 | 89 | 100 | 97 | 112 |
| 90 | 135 | | 91 | 101 | 98 | 113 |
| 91 | 139 | | | 102 | 99 | 113 |
| 92 | 145 | | | 103 | 100 | |
| 93 | | | | 103 | 101 | |
| 94 | | | | 104 | 101 | |
| 95 | | | | 104 | 102 | |
| 96 | | | | 105 | 102 | |
| 97 | | | | 106 | 103 | |
| 98 | | | | 107 | | |
| 99 | | | | 108 | | |
| 100 | | | | 108 | | |

Approximate Conversion Chart GYZJ-935 and GYZJ-936

| GYZJ-935 & 936 | Type D Durameter | |
|----------------|------------------|----------|
| | GYZJ-935 | GYZJ-936 |
| 4 | 64 | 52 |
| 6 | 65 | |
| 8 | | 66 |
| 10 | 67 | |
| 12 | | 68 |
| 14 | 69 | |
| 16 | | 70 |
| 18 | 71 | |
| 20 | | 72 |
| 22 | 73 | |
| 24 | | 74 |
| 26 | 75 | |
| 28 | | 76 |

| GYZJ-935 & 936 | Type D Durameter | |
|----------------|------------------|----------|
| | GYZJ-935 | GYZJ-936 |
| 30 | 70 | 60 |
| 32 | | 71 |
| 34 | 72 | |
| 36 | | 73 |
| 38 | 74 | |
| 40 | | 75 |
| 42 | 76 | |
| 44 | | 77 |
| 46 | 78 | |
| 48 | | 79 |
| 50 | 80 | |
| 52 | | 81 |
| 54 | 82 | |
| 56 | | 83 |

| GYZJ-935 & 936 | Type D Durameter | |
|----------------|------------------|----------|
| | GYZJ-935 | GYZJ-936 |
| 58 | 78 | 72 |
| 60 | 79 | 73 |
| 62 | | 74 |
| 64 | 80 | 75 |
| 66 | 81 | 76 |
| 68 | 82 | 77 |
| 70 | | 78 |
| 72 | 83 | 79 |
| 74 | 84 | 80 |
| 76 | 85 | 81 |
| 78 | | 83 |
| 80 | 86 | 84 |
| 82 | 87 | 85 |
| 84 | 88 | 86 |
| 86 | 89 | 87 |
| 88 | n/a | 89 |

The Impressor

Ordering Information

Hardness Tester

| Model | Range |
|----------------|--|
| GYZJ-934-1 | 25 to 150 Brinell (10 mm ball 500 kg load) |
| GYZJ-934-1-0-1 | For ladder testing (NFTA and ASTM compliant) |
| GYZJ-935 | For softer plastic and very soft metals |
| GYZJ-936 | For extremely soft material |

Certified Test Disks

| Part No. | Use with Model | Barber-Colman Scale |
|--------------|---------------------|---------------------|
| GYZJ-069-100 | Set of 5 GYZJ-935 | 87 – 89 |
| GYZJ-070-100 | Set of 5 GYZJ-936 | 48 – 50 |
| GYZJ-078-100 | Set of 5 GYZJ-934-1 | 43 – 48 |
| GYZJ-250-100 | Set of 5 GYZJ-934-1 | 87/89 |

Non-certified Test Disks

| | | |
|----------|-----------------|---------|
| GYZJ-069 | Each GYZJ-935 | 87 – 89 |
| GYZJ-070 | Each GYZJ-936 | 48 – 50 |
| GYZJ-078 | Each GYZJ-934-1 | 43 – 48 |
| GYZJ-250 | Each GYZJ-934-1 | 87/89 |

The Impressor Repair Parts

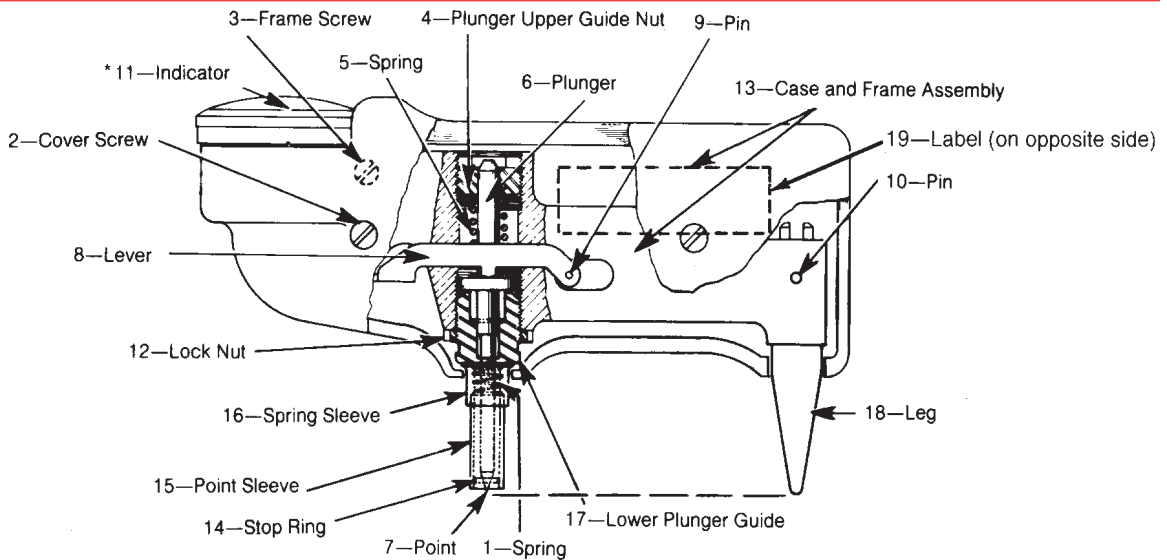

| Item | GYZJ-934-1 | GYZJ-935 | GYZJ-936 | Description | Qty |
|------|------------|-------------------------------|------------|----------------------------------|-----|
| 1 | AYRS-62 | AYRS-62 | AYRS-62 | Spring | 1 |
| 2 | BYRF-3114 | BYRF-3114 | BYRF-3114 | Cover Screw | 2 |
| 3 | BYRF-250 | BYRF-250 | BYRF-250 | Frame Screw | 1 |
| 4 | GYZJ-2 | GYZJ-2 | GYZJ-2 | Plunger Upper Guide Nut | 1 |
| 5 | GYZJ-3 | AYRS-146-1 | AYRS-146-1 | Spring† | 1 |
| 6 | GYZJ-4-1 | GYZJ-4-1 | GYZJ-4-1 | Plunger | 1 |
| 7 | GYZJ-6-5 | GYZJ-6-5 | GYZJ-67 | Indenter Point† | 1 |
| 8 | GYZJ-7 | GYZJ-7 | GYZJ-7 | Lever | 1 |
| 9 | GYZJ-8 | GYZJ-8 | GYZJ-8 | Pin | 1 |
| 10 | DYRA-218 | DYRA-218 | DYRA-218 | Pin | 1 |
| 11 | GYZJ-15-2 | GYZJ-15-2 | GYZJ-15-2 | Indicator (not field servicable) | 1 |
| 12 | GYZJ-16 | GYZJ-16 | GYZJ-16 | Lock Nut | 1 |
| - | GYZJ-17-1 | GYZJ-17-1 | GYZJ-17-1 | Wrench | 1 |
| - | GYZJ-19-2 | GYZJ-19-2 | GYZJ-19-2 | Carrying Case | 1 |
| 13 | GYZJ-23-1 | GYZJ-23-1 | GYZJ-23-1 | Case & Frame Assembly | 1 |
| 14 | GYZJ-61 | GYZJ-61 | GYZJ-61 | Stop Ring | 1 |
| 15 | GYZJ-62 | GYZJ-62 | GYZJ-62 | Point Sleeve | 1 |
| 16 | GYZJ-63 | GYZJ-63 | GYZJ-63 | Spring Sleeve | 1 |
| 17 | GYZJ-64 | GYZJ-64 | GYZJ-71 | Lower Plunger Guide† | 1 |
| 18 | GYZJ-65 | GYZJ-65 | GYZJ-65 | Leg | 1 |
| 18 | GYZJ-65-4 | For Model GYZJ-934-1-0-1 only | | Leg | 1 |
| 19 | GYZJ-79-1 | GYZJ-79-2 | GYZJ-79-3 | Label† | 1 |

† Parts required to convert between models.